

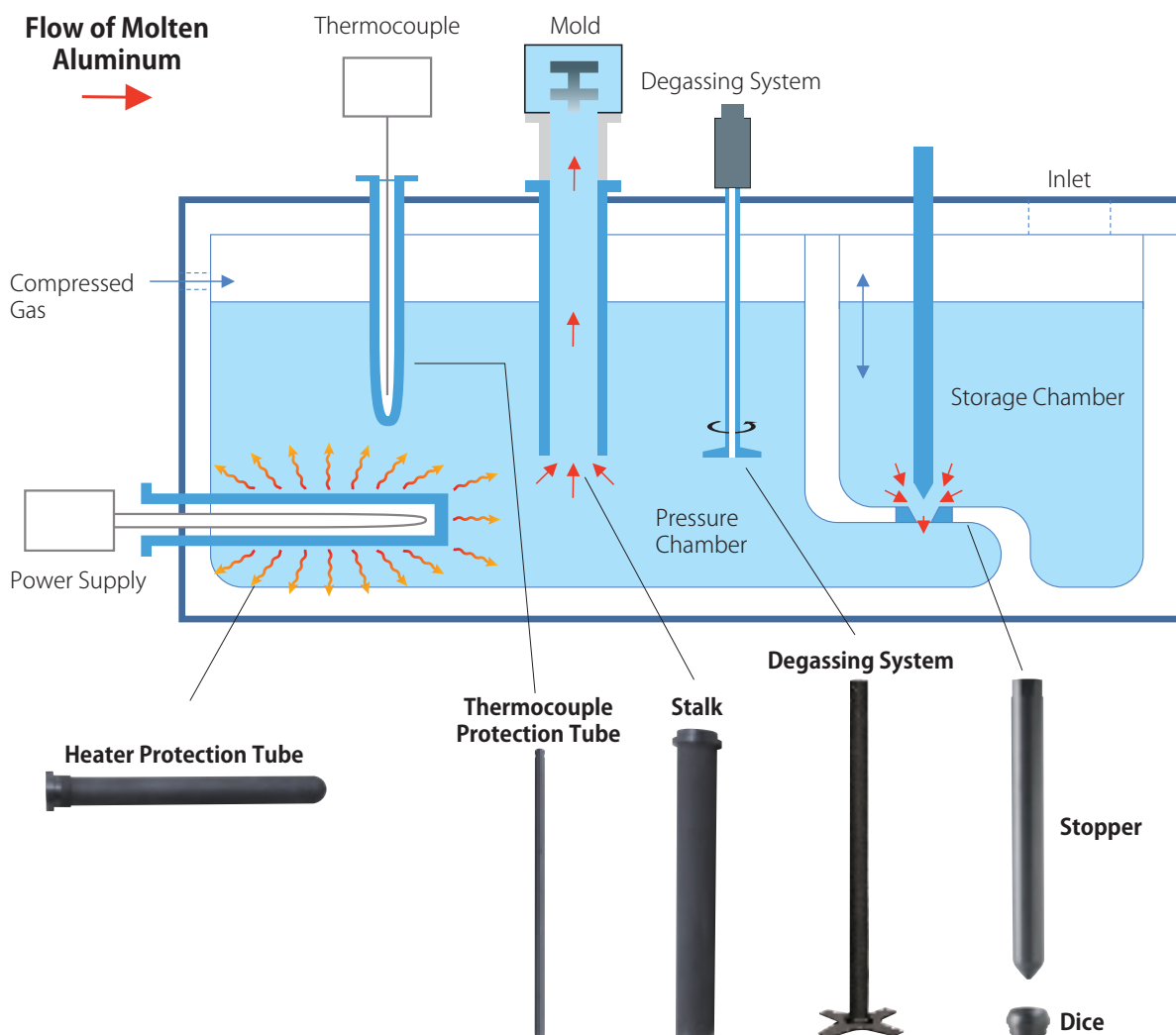

Kyocera's Fine Ceramics have superior characteristics in mechanical strength, wear resistance and corrosion resistance. They are widely used in industrial machinery and for other applications. Among them, silicon nitride ( $\text{Si}_3\text{N}_4$ ) and aluminum titanate ( $\text{Al}_2\text{TiO}_5$ ) are known for their excellent thermal shock resistance, making them highly reliable even in high-temperature and high-pressure environments. This is why they are widely used as components in the casting process of molten metals.

SN240O developed by Kyocera is a silicon nitride material that enhances thermal and mechanical properties. It contributes to the production of high-quality cast products by minimizing leaching contamination in various equipment handling molten aluminum, such as hot chambers and cold chambers. Additionally, it helps to reduce maintenance costs and improve productivity by extending the lifespan of equipment components.

## Application for Aluminum Foundry & Casting



# Features of Silicon Nitride Fine Ceramics

---

## ● Reducing maintenance frequency and improving productivity

---

Silicon nitride has significantly less reaction and erosion with molten aluminum compared to traditional cast iron and reaction-sintered ceramics. It also has low wettability with molten aluminum, which means less adhesion to the pipe walls, contributing to reduced maintenance frequency. Plus, its high thermal shock resistance makes it easy to handle and manage during preheating.

For example, in the case of stalk, replacements are needed every 2 to 3 years, although regular maintenance is still necessary.

## ● Improving the quality of cast parts

---

Silicon nitride does not react with molten aluminum, so there's no contamination of iron components due to leaching, like you might see with traditional cast iron parts. This means we can achieve higher quality in cast components.

## ● Light and easy handling (safety)

---

Silicon nitride is lightweight and has high strength, showing minimal degradation in strength up to 800 °C. Additionally, it is resistant to erosion and wear from molten aluminum, allowing for thin-walled designs. As a result, the weight of molten metal handling components made from Silicon nitride can be less than half that of cast iron, making it easier to handle.

## ● Energy conservation

---

Silicon nitride has been widely used as protection tubes for heaters, and compared to traditional graphite, it offers higher strength and can be made thinner, which allows for more efficient heat transfer to molten metal. This means that energy consumption can be reduced.

## ● High reliability

---

Silicon nitride has higher reliability compared to traditional ceramics due to its high strength at elevated temperatures and excellent toughness.

We also provide solutions for custom size and spec modification request other than the standard sizes shown in this brochure. Please feel free to contact us if you have special application or requirement.

## ■ Case Study

Examples of increased productivity through reduced maintenance frequency and improved quality by preventing contamination from impurities.

### Challenge

#### Improvement of productivity and quality

The cast iron stalks tend to get wet with aluminum molten metal, which leads to a lot of adhesion to the pipe walls. This means we had to stop the line every time we needed to remove the deposits or apply release agents for maintenance. Also, with cast iron stalks, they might need to be replaced every two weeks due to melting from the aluminum, which severely affects productivity. There is also the issue of impurities mixing into the aluminum molten metal from the release agents and the leaching of cast iron, making it a challenge overall.

### Solution

#### Adoption of Silicon Nitride with high temperature and chemical resistance

### Result

#### Productivity improvement by extending the lifespan of parts and reducing maintenance Quality improvement by preventing contamination with impurities

By changing from cast iron to Fine Ceramics with high heat and corrosion resistance, we succeeded in extending the lifespan of low-pressure casting stalks and improving productivity.

Until now, it had been necessary to replace parts once every two weeks, but parts are now replaced once every one to three years. Furthermore, we were able to reduce the burden of daily maintenance (removal of deposits) by decreasing the amount of deposits.

Since Fine Ceramics possess outstanding corrosion resistance, we were able to eliminate impurities resulting from molten aluminum erosion, which occurred when using a cast iron stalks. As a result, the customer was able to manufacture higher-quality cast parts.

Also, the specific gravity of silicon nitride is about 50% lower than cast iron. This makes it easier to handle the stalk during maintenance and replacement.

Moreover, since silicon nitride has lower thermal conductivity compared to cast iron, it has less heat dissipation to the outside, and energy loss was reduced.

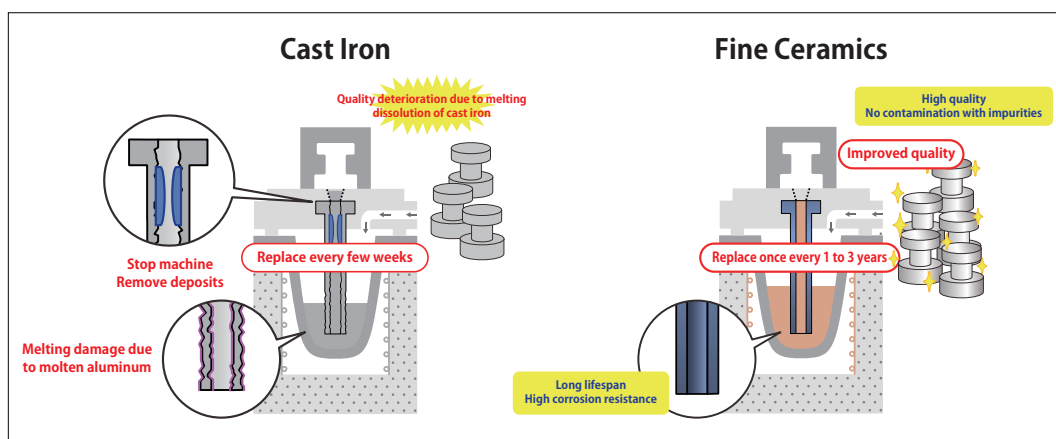

# Material Characteristics Table

Item		Material		Silicon Nitride (Si <sub>3</sub> N <sub>4</sub> )				Aluminum Titanate (Al <sub>2</sub> TiO <sub>5</sub> )	
				SN201B	SN240O	SN241O	SN260A	AT	
Material Code (New)				SN201B	SN240O	SN241O	SN260A	AT	
Material Code (Old)				SN201B	SN240	SN241	SN260	–	
Density(*1)	g/cm <sup>3</sup>	JIS R 1634		3.2	3.3	3.2	3.1	3.4	
Water Absorption	%	JIS C 2141		0	0	0	0	1.2	
Mechanical Characteristics	Vickers Hardness HV9.807N	GPa	JIS R 1610	13.9	14.0	13.8	12.7	3.2	
	Flexural Strength 3P.B.	MPa	JIS R 1601	580	1,020	790	900	30	
	Young's Modulus of Elasticity	GPa	JIS R 1602	290	300	290	270	30	
	Poisson's Ratio	–		0.28	0.28	0.28	0.28	–	
	Fracture Toughness (SEPB)	MPa·m <sup>1/2</sup>	JIS R 1607	4 ~ 5	7	6 ~ 7	6 ~ 7	–	
Thermal Characteristics	Coefficient of Linear Thermal Expansion	40 – 800°C	×10 <sup>-6</sup> /K	JIS R 1618	3.2	3.3	3.5	3.3	0.7
	Thermal Conductivity 20°C		W/(m·K)	JIS R 1611	25	27	54	23	2
	Specific Heat Capacity		J/(g·K)	JIS R 1611	0.64	0.65	0.66	0.66	0.80
	Thermal Shock Temperature Difference(Put in Water, Relative Method)		°C	JIS R 1648	550	800	900	800	–
Electrical Characteristics	Volume Resistivity	20°C	Ω·cm	JIS C 2141	>10 <sup>14</sup>	>10 <sup>14</sup>	>10 <sup>14</sup>	>10 <sup>14</sup>	>10 <sup>8</sup>
		300°C			10 <sup>12</sup>	10 <sup>12</sup>	10 <sup>12</sup>	10 <sup>13</sup>	–
		500°C			10 <sup>10</sup>	10 <sup>10</sup>	10 <sup>10</sup>	10 <sup>11</sup>	–

\*1 : Values mentioned in the table are measured results of test pieces. Actual properties may vary on practical conditions and parts shape. All values for apparent density and bulk density are the same, except for the porous materials which lists apparent density only.

# Characteristics of Fine Ceramics

## High Temperature Strength

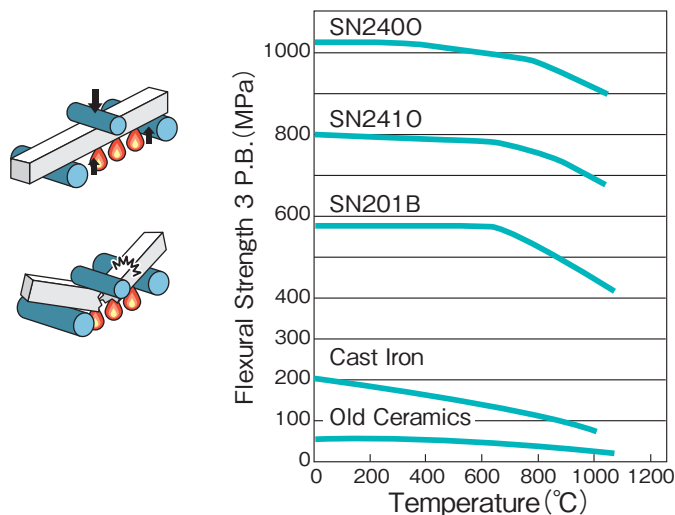

## Heat Shock Resistance

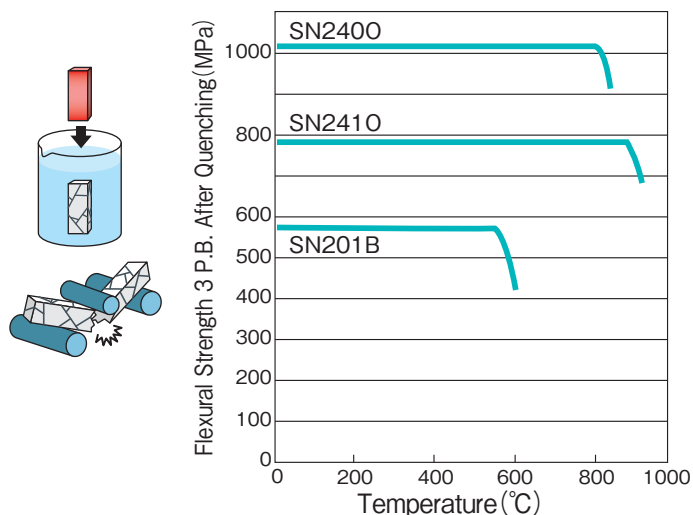

## Chemical Resistance

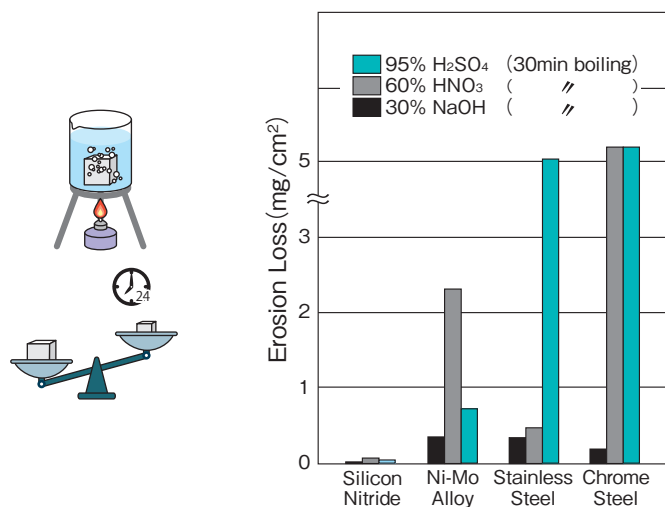

## Reaction Against Molten Metal

Molten Metal	Temperature (°C)	Duration (h)	Result
Al	800	950	○
Pb	400	144	○
Sn	300	144	○
Zn	550	500	○
Mg	750	20	×
Cu	1,150	7	×

Note : ○ ; Not Eroded × ; Eroded

(Source)

Hirai, Matsuda:Journal of High Temperature Science, 3[5], 146 (1977)

J.F. Collins and R.W.Gerby:J.Metals,7,612(1955)

Note : Values mentioned in the table are measured results of test pieces. Actual properties may vary on practical conditions and parts shape.

# Stalk (Feed Pipe)

Stalk is a part used to pour molten aluminum into a mold during the low-pressure casting process

**Material** Silicon Nitride SN2400/SN260A

- Features**
- Thanks to its high thermal shock resistance, it is easy to handle and manage preheating.
  - Low wettability against molten aluminum makes material adhesion on tube less and it makes daily maintenance easier.
  - Superior corrosion resistance does not allow eluted contamination into molten metal. This is a key factor to maintain purity of molten alloys.
  - Compared to reaction-sintered products, they have a dense structure and high strength, which helps to minimize the risk of damage during handling.

**Durability** There are examples of things that have lasted over two years with proper maintenance.

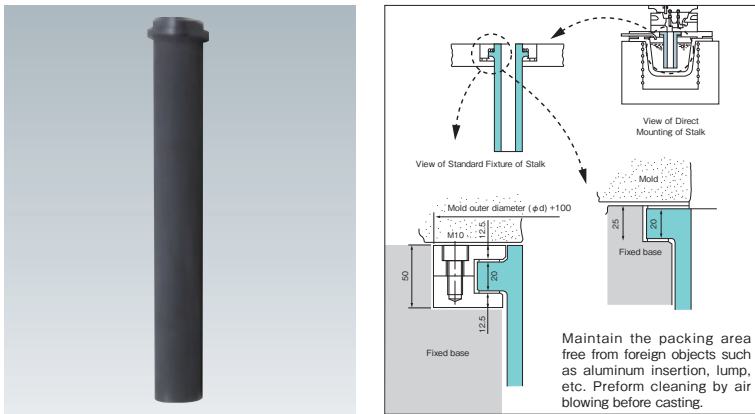

# Heater Tube and Burner Tube

Protects electric heaters and gas burners from high-temperature molten aluminum

**Material** Silicon Nitride SN2400/SN2410

- Features**
- Excellent heat resistance and can withstand severe thermal loads even at high temperatures.
  - When using the vertical immersion shown in the figure below, temperature changes occur on the outer wall of the tube due to fluctuations in the water surface. Silicon nitride has excellent strength and can withstand the thermal stresses generated by these temperature changes.
  - Excellent corrosion resistance and does not leach any components like traditional products made of graphite, so it will not contaminate the molten metal.
  - Resistant to wetting by molten aluminum, easy to maintain and manage, and has excellent durability.

**Durability** There are examples of things that have lasted over two years by vertical immersion and over 3 years by horizontal immersion with proper maintenance.

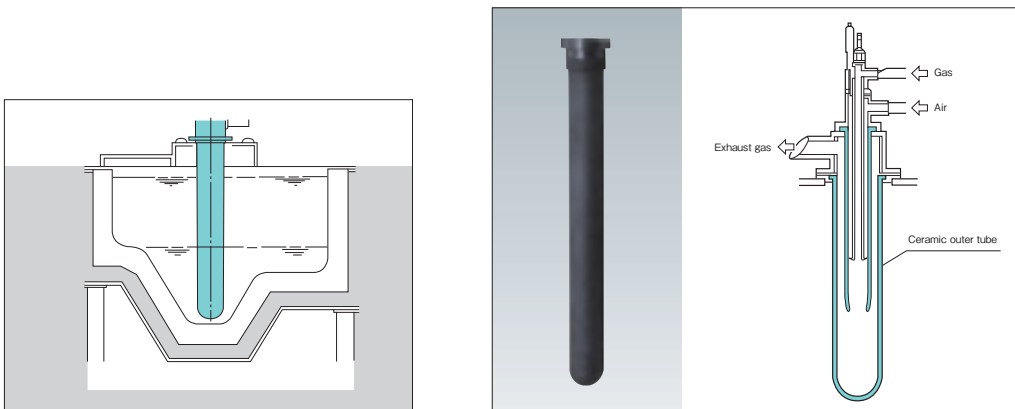

# Protection Tube for Thermocouple

Protects thermocouples from high-temperature molten aluminum, contributing to maintenance-free operation

**Material** Silicon Nitride SN201B/SN240O

- Features**
- Highly resistant to corrosion, doesn't leach, and won't contaminate the molten metal.
  - Excellent thermal shock resistance and easy to handle and preheat.
  - Denser structure and higher strength compared to reaction-sintered products, which helps to reduce the risk of damage during handling.
  - **Even with flux, SN-240/SN-201B are hardly eroded. This ensures long life.**

**Durability**

	with flux	without flux
OLD CERAMICS	2 days ~ 1 months	1 month ~ 2 months
Silicon Nitride (Si <sub>3</sub> N <sub>4</sub> )	6 months ~ 1 year	About 2 years.

Note: Values mentioned in the table may vary on practical conditions.

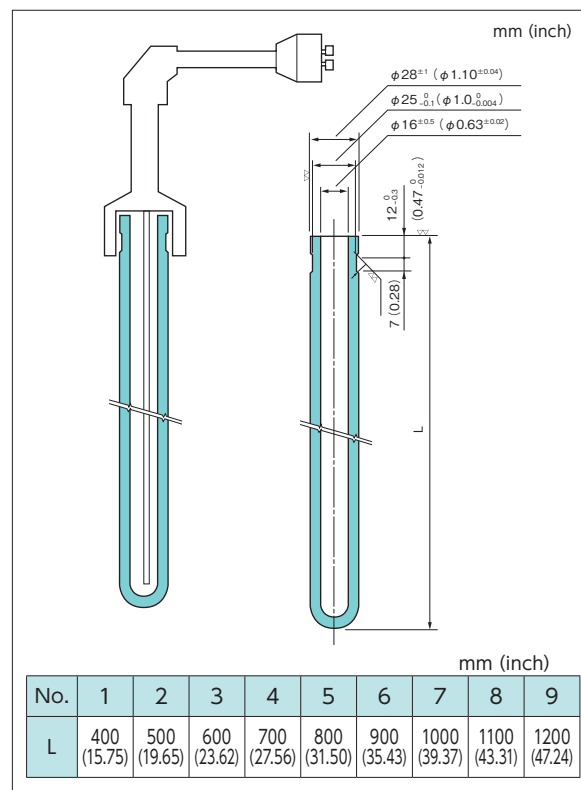

# De-gassing Pipe, Rotor

Component used to inject and diffuse inert gases like N<sub>2</sub> and Ar into molten aluminum. The diffused gas combines with hydrogen and non-metallic inclusions present in the molten aluminum, and thanks to buoyancy, it rises to the surface, where it can be removed, contributing to the purification of the molten metal.

- Material** Silicon Nitride SN2400
- Features**
  - Compared to traditional graphite products, this material has less oxidation wear at high temperatures and excellent durability, allowing it to maintain stable performance over a long period.
  - Because of its high precision and strength, it reduces the risk of damage during high-speed operation.
- Durability** By implementing proper preheating management, we have seen a track record of 1 to 2 years of usage.

## Processing Condition

Aluminum Alloy	AC4CH
Alloy Volume	500kg
Temperature	710°C~720°C
N <sub>2</sub> amount	15ℓ /minute
Flux	NaCl
Rotation Speed	300rpm

Initial hydrogen content : 0.25cc/100gAl

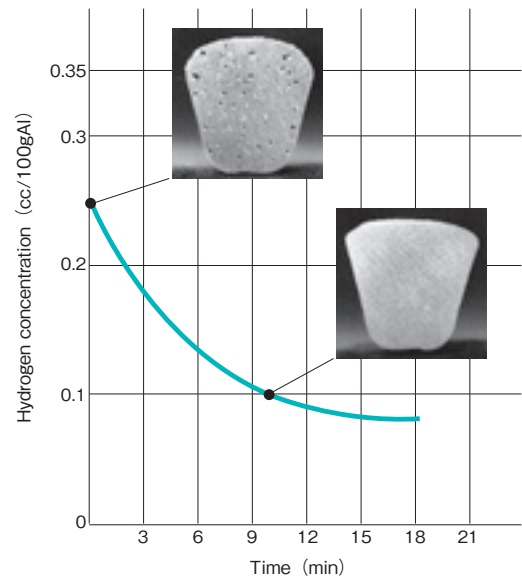

The specific effects of using a degassing pipe and rotor.

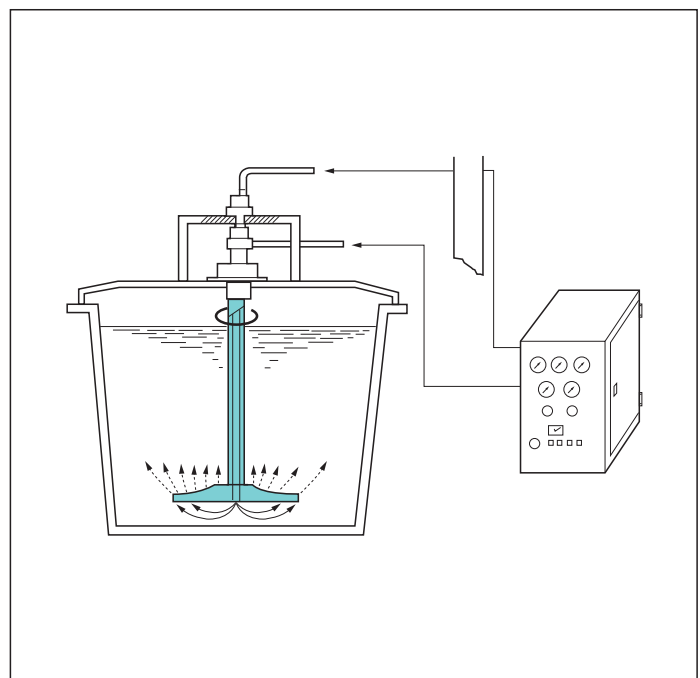

## Stopper, Dice

Set component that acts as a valve when supplying molten aluminum from the holding chamber to the pressurized chamber in a two-pot low-pressure casting furnace

**Material** Silicon Nitride SN240O

- Features**
- Kyocera's high-precision processing technology achieves excellent airtightness in fitting surfaces.
  - By using high-strength, fine-grained silicon nitride, we can achieve excellent resistance to repeated sliding and maintain the initial form for a long time, which reduces maintenance and ensures long-term reliability.
  - Excellent durability due to its high corrosion resistance and non-reactivity with molten aluminum.

**Durability** There are examples of things that have lasted about two years.



## Fixtures for Wetting Process

Various shaped silicon nitride parts can be made by Kyocera's ceramics manufacturing technology. In aluminum foundry, various silicon nitride fixtures and tools are used. Please contact us if you have unique shape fixtures or tools for special application.

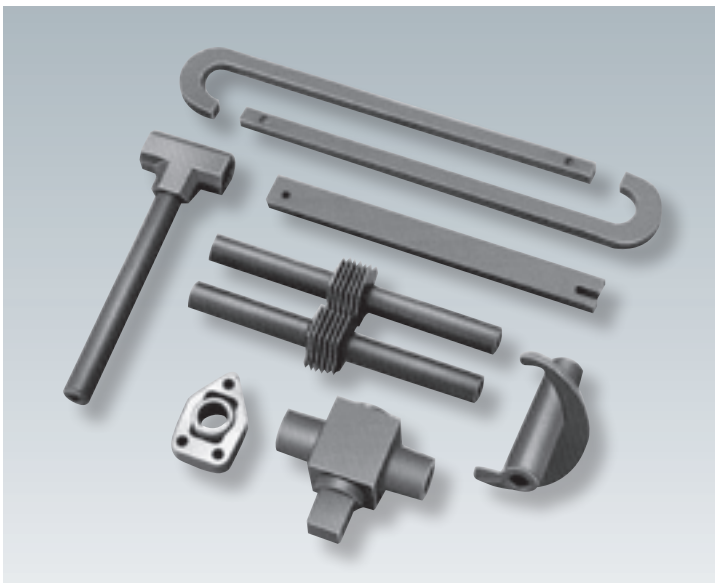

# Types of Fine Ceramics for Industrial Machinery

Many materials have been developed as Fine Ceramics, such as alumina sintered bodies

Kyocera has developed many new materials carving out a name for ourselves as a pioneer in Fine Ceramics. We have already developed more than 200 new materials. These include polycrystalline oxide materials manufactured by a general firing process, such as alumina; nonoxide materials, such as silicon nitride and silicon carbide; and single crystal materials created by crystal control growth technology, such as sapphire. We also mass-produce Fine Ceramic products.

**Alumina  $\text{Al}_2\text{O}_3$**



Alumina was quickly adopted by the electronics industry due to its high electrical insulation properties. In addition, because it has excellent corrosion resistance, wear resistance, and mechanical strength, it is used in many industrial machinery parts, and is the most widely used Fine Ceramic material.

**Sapphire  $\text{Al}_2\text{O}_3$**

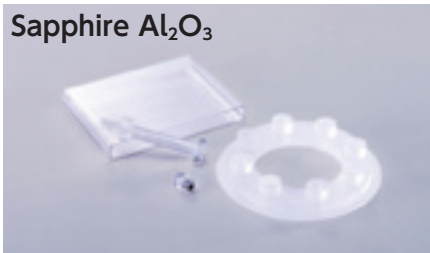

Sapphire, commonly known for the gemstone of the same name, is a single crystal alumina that creates a high-purity, high-performance material. Due to its excellent mechanical properties and chemical stability, it is applied to both mechanical and precision parts. In addition, it is a transparent material and has high optical properties in a wide wavelength range from infrared rays to near-ultraviolet rays. It is easier to mass produce than diamond and has better properties than quartz. It is used in optical components such as sensors and analytical instruments, contributing to longer component life and higher equipment productivity.

**Zirconia  $\text{ZrO}_2$**

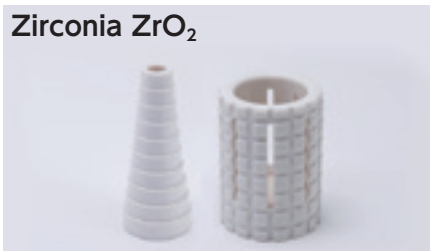

Zirconia is one of the Engineered Ceramics with the highest strength and toughness at room temperature. Due to its excellent surface finish, it is used for sliding parts such as in pumps. With its high toughness and wear resistance, it is also used for industrial cutters, scissors, and kitchen knives, contributing to a longer life for such products. Also, with a beautiful surface obtained by mirror processing, it is used for decorative parts such as in watches.

**Zirconia Toughened Alumina**



Zirconia Toughened Alumina is a composite material made of alumina and zirconia. It has a hardness and bending strength higher than that of alumina, with a lower thermal expansion than zirconia, and is characterized by high thermal conductivity. Taking advantage of its high wear resistance, it is widely used for wear-resistant parts that require cooling, including crusher parts.

**Cordierite  $2\text{MgO}\cdot 2\text{Al}_2\text{O}_3\cdot 5\text{SiO}_2$**

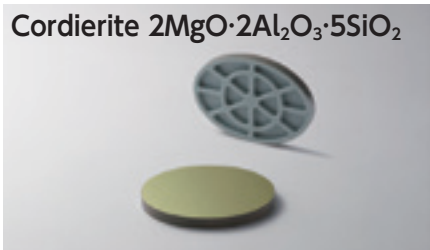

Cordierite has a very small coefficient of linear thermal expansion and has a higher specific rigidity than glass-based materials. Taking advantage of these characteristics, it is used for structural parts in semiconductor processing equipment. It is also used as a mirror due to its high surface smoothness. In the field of astronomy and aerospace, it is applied to light observation in various wavelengths and for optical communication. It is also used as an optical system by assembling multiple cordierite components.

**Cermet  $\text{TiC}\cdot\text{TiN}$  (Ceramic and metal composites)**

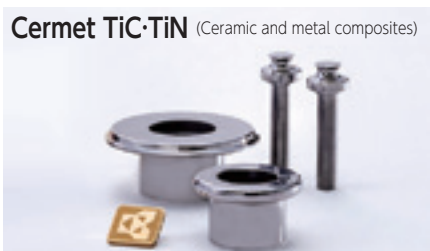

Cermet is a composite material containing titanium carbide (TiC) and titanium nitride (TiN) as the main components, with metals such as cobalt (Co), nickel (Ni), and molybdenum (Mo). It is about three times stronger than alumina ceramics and has excellent wear resistance. It demonstrates high performance when used in cutting tools or industrial cutters. It is also used as a decorative part because mirror processing can make it shiny like a precious metal.



Yttria is a material with excellent plasma resistance. It is effective in reducing contamination by particles and impurities, which is desired for parts in manufacturing processes that use plasma such as semiconductor processing equipment.



YAG-Dispersed Alumina is a material with improved plasma resistance by dispersing yttria and other materials within it. It also has the similar strength as alumina, so there's less risk when handling parts.

\*YAG:  $Y_3Al_5O_{12}$  (Yttrium/Aluminium/Garnet)

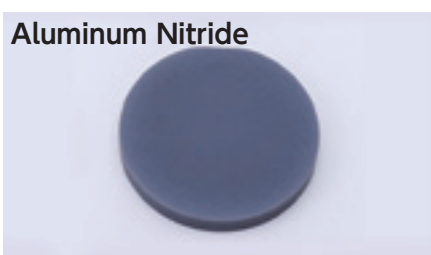

Aluminum Nitride has high thermal conductivity and electrical insulation properties, and is used for heat dissipation or heat uniformity parts, such as those found in semiconductor processing equipment.



Silicon Nitride is an outstanding Fine Ceramic material with high strength that it maintains even at high temperatures and excellent heat shock and wear resistance. Taking advantage of these characteristics, it is used in a wide range of industries, including parts for molten metal casting, steel manufacturing, milling, and automobile parts.

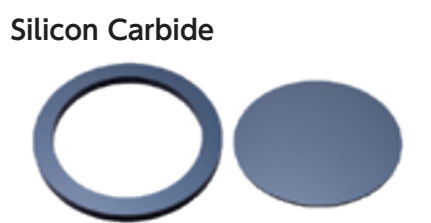

Silicon Carbide is one of the hardest Fine Ceramics materials and exhibits high chemical resistance. Especially, solid-phase sintered silicon carbide is an excellent heat-resistant material that does not deteriorate in strength even at 1400°C.

Furthermore, it is used in a wide range of industries, including mechanical seals and pump parts due to its excellent sliding properties, and semiconductor processing equipment and general industrial machine parts due to its high thermal conductivity and electrical semi-conductivity.



Silicon-Infiltrated Silicon Carbide is a silicon infiltrated composite material based on silicon carbide. Due to the infiltration of silicon, there are less pores and outgassing is suppressed. The material has a high specific rigidity with similar characteristics to Silicon Carbide and lower electrical resistance than Silicon Carbide, making it possible to eliminate static electricity from parts. Its unique manufacturing method and reactive sintering bonding facilitate the production of large, complex-shaped parts or hollow structures, and are widely used in applications such as semiconductor processing equipment.



This material has excellent thermal insulation and thermal shock resistance. Its poor wettability with molten aluminum makes it widely used in aluminum casting processes.

# Manufacturing Process (Polycrystal)

<h3>Raw Material Processing</h3> <ul style="list-style-type: none"> <li>- Mill the raw material to achieve uniform particle size and mix with the binder. Then dry in a dryer to produce highly fluid granules.</li> </ul>	<h3>Forming Process</h3> <ul style="list-style-type: none"> <li>- Material powders are solidified and formed into a shape close to that of the finished product.</li> <li>- The formed part is designed with consideration of sintering shrinkage and grinding / polishing margin. Green machining is performed as necessary to bring it closer to the product shape.</li> </ul>
--	--



<b>Compounding / Milling / Mixing</b>	<b>Spraying &amp; Drying</b>	<b>Forming</b>	<b>Green Machining</b>
---------------------------------------	------------------------------	----------------	------------------------

### Ball Mill

Raw materials, binder, balls, and water are put into the mill, then milled and mixed repeatedly to achieve uniform particle size of the raw materials and make a slurry.

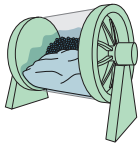

### Spray Drying

The slurry is sprayed and instantly dried with hot air to form granules.

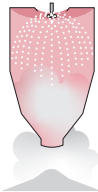

### CIP (Cold Isostatic Pressing)

A rubber mold filled with raw material powders is placed into a water tank in a high pressure vessel and water pressure is applied.

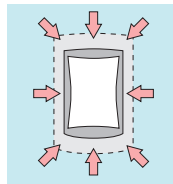

### Green Machining

A pressure-formed round bar or square lumber is cut into shapes containing 20% volume which shrinks by the sintering.

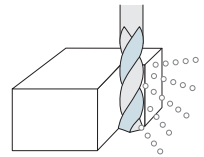



**OPTION**

We have unique grinding methods and equipment to meet our production volume and various raw material types.

### Bead Mill

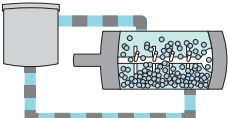
A small mill and a drum are connected with a pipe to circulate raw materials, binders, and water, and the particle size is refined by repeating milling and mixing many times.





**OPTION**

We select an efficient method suitable for size, shape, and quantity from various forming methods.

### Die Pressing (Press Forming)

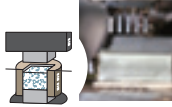
A die with a split structure close to the final shape is filled with powder and then pressed.



### Injection Molding

Plastic resin is added to the raw material and injected into the mold while heating.

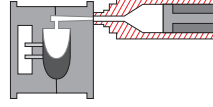

### Tape Molding (Roll Compaction)

Powders are pressed into a sheet by rollers.

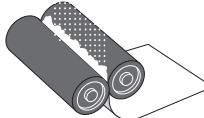

### Cast Molding

The fluid raw material is poured into a plaster mold, and then the mold is removed after drying.

## Sintering Process

- The formed part is sintered at a temperature of 1000°C or higher. During the sintering process, powder particles are fused together to form a dense and extremely hard part.
- \*Sintering process shrinks the dimensions by 20% and the volume by 50%.



## Grinding Process

- The sintered part, which now has the hardness close to diamond, is ground to the final specifications with a designated grinding tool, and the surface is polished.
- We have machining technology to meet a wide variety of requests, including complicated shapes, high precision specifications, and in combination with other materials.



## Inspection / Cleaning / Packaging

- Processes to deliver high quality products.
- Inspection, cleaning, and packaging suited for product specifications.



### Sintering

### Grinding

### Polishing

### Inspection / Cleaning / Packaging

#### Batch Furnace

Sintering at a temperature of 1000 °C or higher is achieved by strictly controlling the atmospheric gas temperature in accordance with the size of the product and the material being used.

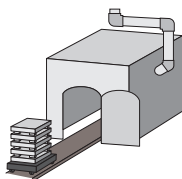

#### Grinding

A sintered material is ground with diamond tools to form the final shape.

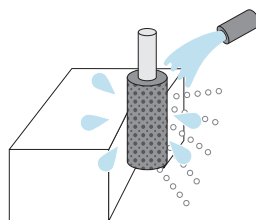

#### Polishing

Finish to face accuracy according to specifications.

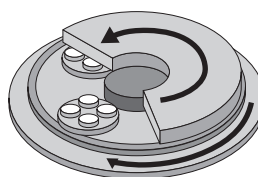

#### Inspection

High quality is assured by using high-precision measuring equipment and other devices.



#### Cleaning

Impurities are removed based on requirement.



#### OPTION

We have various sintering furnaces suited for material types, product sizes and shapes, with the know-how of optimum temperature control.

#### Tunnel Kiln

Suitable for small products with a fast sintering cycle.



#### Vacuum Furnace / Atmospheric Furnace

After being rendered a vacuum, the inside of the furnace is filled with an inert gas and used for firing sintered non-oxides.

#### Hot Pressing

Material powders are placed in a mold and sintered at high temperature while applying pressure in a uniaxial direction. The part becomes void-less in the direction of the pressure, leading to improved properties.

#### HIP (Hot Isostatic Pressing)

After pre-sintering, the product is placed in a pressure vessel, and high isotropic pressure is applied with heat to make a high-density sintered body.

#### OPTION

We have a large number of manufacturing technologies that enhance the functions and added value of ceramic parts, and we continue to develop new processes.

#### Laser Processing

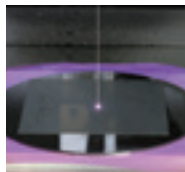

#### Coating

#### Metallization

Firmly bond Fine Ceramis with metal

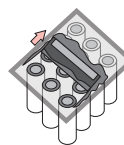

#### Joining

#### OPTION

We are equipped to achieve the high level of cleanliness required for components to be installed in medical and analytical equipment, semiconductor manufacturing equipment, etc.

#### Ultra-Precision Cleaning Line

Removes small particles such as deposits and airborne particles from the manufacturing process



### Smart Factories

In order to meet various demands, designing and manufacturing process selection are important, on top of abundant material equipment and manufacturing technology. We are responding to the product realization satisfying specifications by efficient designing that makes full use of IT in addition to abundant ceramic design know-how.

In addition, by utilizing smart factories, we have a stable supply capacity that is not affected by changes in the environment. We are also working on the automation of production lines that continue improvement by accumulating manufacturing data and by AI analysis.





# KYOCERA Corporation

## Corporate Fine Ceramics Group

<https://global.kyocera.com/prdct/fc/>

Kyocera Fine Ceramics 

Product Inquiries→



The contents of this catalog are subject to change without prior notice for future improvement.  
Application and the using conditions are required to be consulted when considering to purchase.

**Duplication or reproduction of any part of this brochure without approval is prohibited.**

© 2025 KYOCERA Corporation 041/004/2508 Printed in Japan